

Anti-collision optical detector for travelling cranes

Red light

RXC 3 series



Safety

- Optical and electronic components continuously self-tested
- Maximum operating distance: 30 m, recommended working distance: 20 m max.
- "Positive Safety" electrical operation
- Reliable detection distance by triangulation
- Integrated alignment assistance system
- Remote alert system for preventive maintenance

Vibration withstand capacity

- Screw-less terminal strip with stripping gauge
- Firmly secured components
- "Industrial" mounting system (M8 and 2xM6)

Housing designed for industrial environment

- Anti-mist / anti-ice optical system
- Glass lens
- Tightness rating IP65
- Operating temperature range: - 30° to + 65°C
- Anti-corrosion treated metal housing
- Protective visor (shocks / streaming water)
- Cable gland through rear or bottom
- High protection against electromagnetic disturbance (better than level 4 according CEI 1000-4-4)



Bi-voltage power supply

- 24/48 VAC
- 110/230 VAC

Outputs

- By two relays with change-over contacts NO/NC, potential-free
- Crane stop output: contact closed in absence of reflector. Contact opens when reflector is detected or power cut-out occurs
- Technical alarm output: normally closed. Contact opens if fault is detected in reception circuit.
- Characteristics of contacts
 - Response time: 15 ms
 - Breaking capacity: AC1 10A/250 VAC
AC15 3A/250 VAC
AC13 2A/24 VDC
- Service life on standards contactors:
 - 230 VAC : 8 millions cycles
 - 24 VDC : 5 millions cycles

Display by multifunction indicator light

- Red 3-state indicator light (beam presence)
 - on: beam established
 - off: beam interrupted
 - flashing: beam established but signal margin is insufficient.
- Green (self-test)
 - on: system OK
 - off: fault, technical alarm output has tripped.

Recommended reflectors

- Distance < 5 meters
 - WAB 600 (175x175 mm)
 - WAB 660 (600x235mm) for better stopping precision.
- Distance > 5 meters
 - WAB 660 (600x235 mm)

INSTALLATION:

- The system works by triangulation as indicated opposite.
- The edges of the WAB reflector and the RXC detector must be aligned on the crane translation axis.

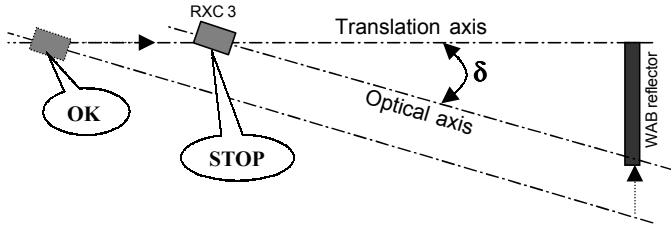
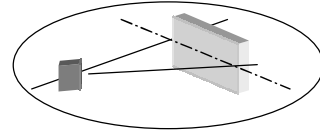

To adjust the detector:

- Place the crane at the desired stopping distance.
- Adjust the angle δ so that the RXC is triggered when the beam hits the WAB.

Use the multifunction indicator lights and the red emission to adjust the detection geometry.

DIMENSIONS AND MOUNTING:

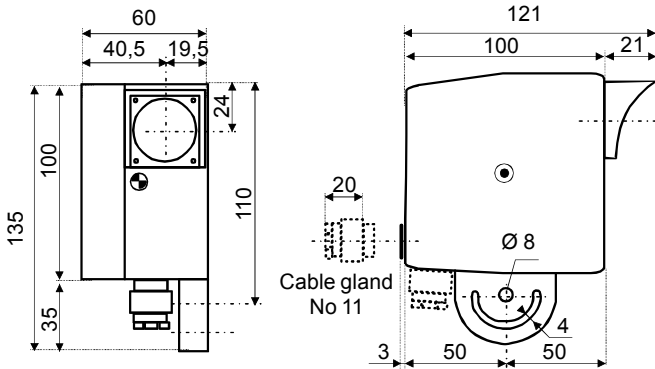

WAB 600

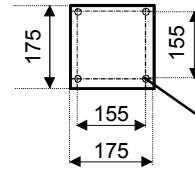

WAB 660

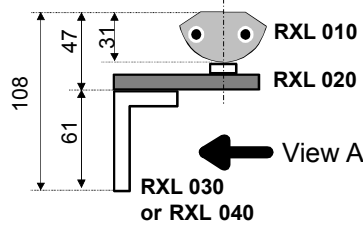
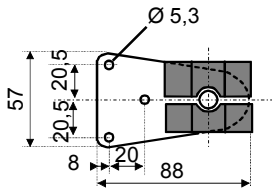
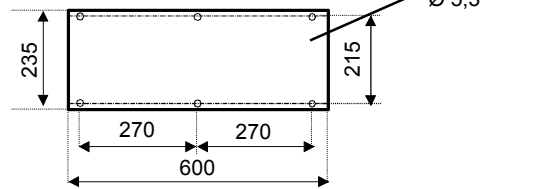

RXL 030

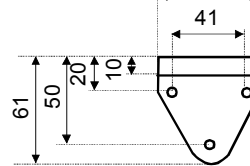

RXL 040

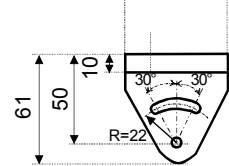

(View A)

CONNECTION:

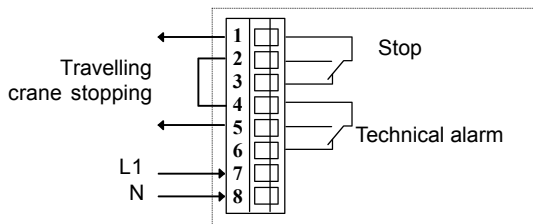

MOUNTING ACCESSORIES:

- On rod Ø14 to 18mm: RXL010
- On horizontal surface: RXL040 or RXL010 + RXL020
- On vertical surface: Direct or RXL010 + RXL020 + RXL030

ORDERING DATA:

Detector:

- 24/48 VAC **RXC 31A**
- 110/230 VAC **RXC 31B**

Accessories: (ordered separately, according to installation)

- Mounting clamp **RXL 010**
- Horizontal plate **RXL 020**
- Return bracket **RXL 030**
- Plain bracket **RXL 040**

The products described in this document are subject to change. Descriptions and characteristics are not contractual.



Head office and factory : GRENOBLE -
 176, rue Lavoisier - MONTBONNOT ST MARTIN
 F - 38334 ST ISMIER CEDEX
 Tel : +(33) 4 76 41 44 00
 Fax : +(33) 4 76 41 44 55



Distributor